



### OC169



[Upload & Info »](#)

[My Tube/Semi »](#)

ID = 33838



**Country:** Germany    **Brand:** [Valvo GmbH, Radioröhrenfabrik; Hamburg](#)  
**Tube type:** Transistor RF/IF-Stage

**Identical to**    **OC169** = [OC169R](#)

**Other shape (e.g. bulb type):**

[AF126](#) ; [AF127](#) ; [AF132](#) ; [AF136](#) ; [AF137](#) ; [AF138](#) ; [AF200](#) ; [GF120](#) ;  
[GF121](#) ; [OC390](#) ; [OC44](#) ; [OC612](#) ; [OC613](#) ; [OC881](#) ; [SFT316](#)

**Normally replaceable-slightly different:**

[2G138](#) ; [2N1121](#) ; [2S98](#) ; [2S99](#) ; [2SA68](#) ; [2SA69](#) ; [2SA97](#) ; [2SA98](#) ;  
[DS-22](#) ; [DS-24](#) ; [DS-25](#) ; [OC160](#)

**Different maximum ratings:**

[2SA49](#) ; [AF116](#) ; [AF117](#)

**First Source (s)**    Mar.1958 : Valvo-Berichte

**Predecessor Tubes**    [OC44](#)   [OC45](#)   [OC160](#)

**Successor Tubes**    [AF117](#)

**Base**    Wires

**Filament**    Solid State

**Description**    PNP germanium diffusion alloy transistor intended as AM IF amplifier.  
Also made by Philips and related manufacturing plants.  
[Text in other languages \(may differ\)](#)

**Dimensions (WHD) incl. pins / tip**    8 x 9 x mm / 0.31 x 0.35 x inch

**Weight**    4 g / 0.14 oz

**Information source**    -- Collector info (Sammler)    KTT 1969/70

*wird mit R 7 eingestellt*

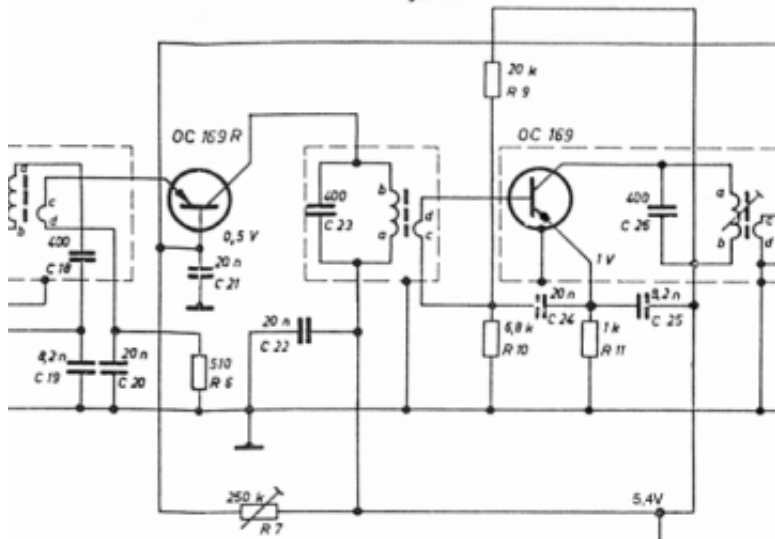

OC169: Braun T22  
Günther Stabe



OC169: Sammlung  
Wolfgang Bauer

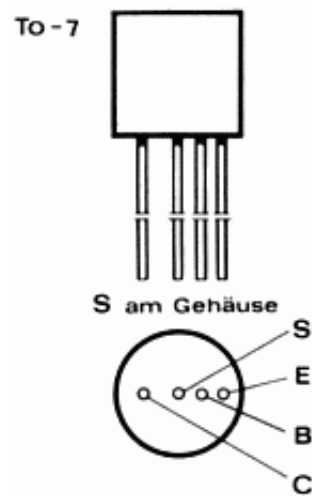

OC169: TVT 73  
Günther Stabe

| No. | Bezeichnung | Werte                               |
|-----|-------------|-------------------------------------|
| 1   | OC 169      | PNP-Germanium-Diffusions-Transistor |
| 2   | OC 169 R    | PNP-Germanium-Diffusions-Transistor |
| 3   | OC 169 S    | PNP-Germanium-Diffusions-Transistor |
| 4   | OC 169 T    | PNP-Germanium-Diffusions-Transistor |
| 5   | OC 169 U    | PNP-Germanium-Diffusions-Transistor |
| 6   | OC 169 V    | PNP-Germanium-Diffusions-Transistor |
| 7   | OC 169 W    | PNP-Germanium-Diffusions-Transistor |
| 8   | OC 169 X    | PNP-Germanium-Diffusions-Transistor |
| 9   | OC 169 Y    | PNP-Germanium-Diffusions-Transistor |
| 10  | OC 169 Z    | PNP-Germanium-Diffusions-Transistor |

OC169: Hersteller  
Karl-Heinz Entrich

**Usage**    [2= 1958](#) ; [1= 1959?](#) ; [8= 1959](#) ; [6= 1960??](#) ; [15= 1960?](#) ; [58= 1960](#) ; [5= 1961??](#) ; [8= 1961?](#) ; [57= 1961](#) ;  
**in**    [6= 1962??](#) ; [8= 1962?](#) ; [26= 1962](#) ; [2= 1963??](#) ; [2= 1963?](#) ; [14= 1963](#) ; [1= 1964?](#) ; [3= 1965??](#) ; [2= 1966](#) ;  
**Models**    [2= 1970??](#) ; [1= 9999?](#)

**Quantity of Models at Radiomuseum.org with this tube (valve, valves, valvola, valvole, válvula, lampe): 227**

[Collection of Wilfried Hofmüller \(A\)](#)

[Collection of Egon Strampe \(D\)](#)

[Collection of Wolfgang Bauer \(A\)](#)

[Collection of Nikolaus Löwe \(D\)](#)

[Collection of Peter Roggenhofer † 25.4.18 \(A\)](#)

Collection of a member from FIN

[Collection of Stig Comstedt \(S\)](#)

[Collection of Karl-Heinz Entrich \(D\)](#)

You reach this tube or valve page from a search after clicking the "tubes" tab or by clicking a tube on a radio model page. You will find thousands of tubes or valves with interesting links. You even can look up radio models with a certain tube line up. [rmxtube-en]

[About Radiomuseum.org](#) | [Contact](#) | [Press](#) | [Privacy](#) | [Copyright](#) | [Logos](#) | [send2friend](#)

High Quality & Quick Turn UK PCB Manufa  
From prototyping to full production  
PCB Online Quotes & PCB Assembly

